

METER PIT DOOR
DETAIL A

PIPE SIZE	3" - 4"	6" - 8"	10"
A	8'-6"	11'-6"	13'-6"
B	4'	5'	5'-6"
C	4'	4'-6"	5'
D	8"	13"	16"
E	14"	19"	20"
APPROXIMATE WEIGHT(LBS)			
FLOOR	5800	8800	10900
WALLS	8100	11850	15000
TOP	3900	6300	7050

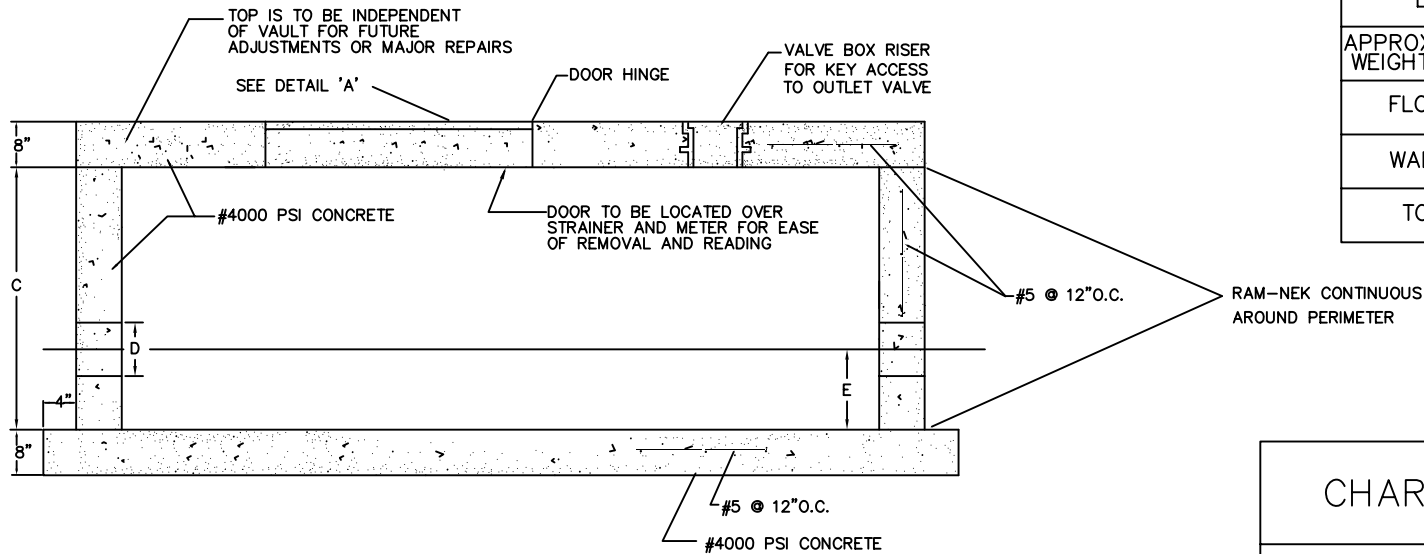

PRECAST VAULTS

CHARLESTON WATER SYSTEM

PRECAST VAULTS

APPROVED BY: CWS	DATE: MAR 2006	DRAWING NO. 26
SCALE: NTS	REVISED: FEB 2010	