

TOP AND FRAME

- NOTES:**
1. BENCH CAN BE PRECAST, OR BRICK AND MORTAR TROWELED SMOOTH.
 2. MANHOLE SHALL BE UNLINED UNLESS IT IS THE RECEIVING MANHOLE FOR A FORCE MAIN OR THE NEXT MANHOLE DOWNSTREAM.
 3. MANHOLES OVER 8 FT. DEEP SHALL HAVE A 60" MINIMUM INSIDE DIAMETER.
 4. THE FRAME AND COVER AND GRADE RINGS SHALL BE SECURED TO THE CONE WITH CONWRAP CS-17.
 5. MANHOLE STEPS ARE NOT ALLOWED.

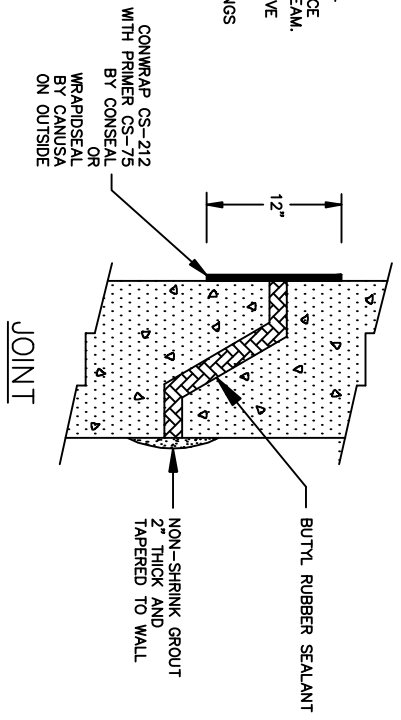

ECCENTRIC CONE PRECAST MANHOLE

<p>CHARLESTON COMMISSIONERS OF PUBLIC WORKS</p>		<p>DRAWING NO. 47</p>
<p>ECCENTRIC CONE PRECAST MANHOLE</p>		
APPROVED BY:	DATE:	
CPW	MAR 2000	
SCALE:	REVISED:	
NTS	OCT 2011	